

INSTALLATION INSTRUCTIONS

Failure to follow these instructions can severely shorten the life of this part and may void the part's warranty.

Installation Process

- 1) Remove distributor noting rotor position. Unit must be reinstalled in same position to ensure correct firing order and that distributor drive tang will engage with oil pump. Do not rotate engine otherwise rotor, cam gear and oil pump drive will be out of synchronization.
- 2) Drift out drive gear retaining pin to remove distributor gear. Note stack order of any washers or spacers beneath gear.
- 3) Slide shaft out of distributor.
- 4) Remove C-clip retaining pick up coil, disconnect pick up leads from module, and remove coil. Vacuum canister retaining screws may be loosened or removed for ease of disassembly.
- 5) Install new pickup coil and C-clip retainer.
- 6) Reconnect leads to module and tighten vacuum canister retaining screws if loosened.
- 7) Reinstall distributor shaft, gear, and gear roll pin. Ensure roll pin is tight fit and not deformed or cracked.
- 8) Slowly rotate shaft to ensure stator teeth on pick-up and shaft do not interfere. Check should be performed with and without vacuum applied to vacuum advance canister.
- 9) If clearance is not adequate, loosen pick-up adjustment screws and center pick up stator assembly. Once centered, slowly and evenly retighten pick-up adjustment screws using caution not to over tighten.
- 10) Reinstall distributor noting original rotor position.

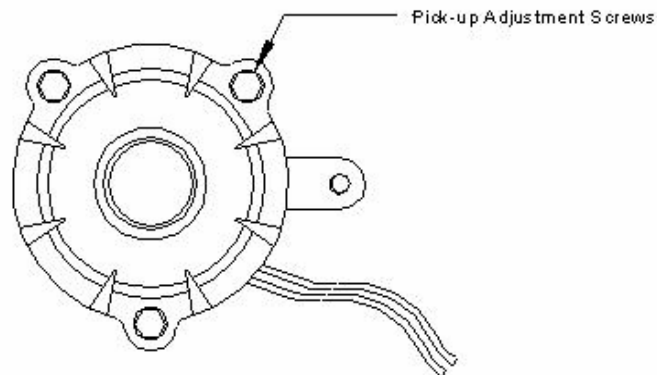

Models Covered: 6181, 6182, 6183, 6188, 6192, 6196, 6204, 6205, 6206, 6207, 6213, 6214, 6217.